

Operation Instruction for Voltage/mA Source

INDEX

1. Safety Information.....	1
2. Instrument Panel Layout and Function.....	3
3. Replacing the Battery.....	4
4. Power-on/off of Calibrator	5
5. Output from Calibrator	5
6. Other Features.....	9
7. Performance Capabilities.....	9
8. Calibration.....	11
9. Points for Attention to Use of Operation Instruction.....	14

1. Safety Information

To ensure the safety operation, the following signs are used only as specified in this operation instruction.

Warning

A warning shows that if the operation does not comply with the following correct instruction, it is possible to bring hazards to the user or cause damage to the calibrator in use. The warning also points out how to avoid the accidents.

! Caution

A caution shows that if the operation does not comply with the following correct instruction, it is possible to cause damage to the calibrator in use. The caution also points out how to avoid maloperation.

Note

A note serves as sign to remind the user that he must understand the correct operation of the calibrator and its characteristics.

To prevent the user and the calibrator from any electric shock and other hazards, it is necessary to observe the following regulations:

Warning

- Do not operate the calibrator at the working field where there exists flammable gas or explosive gas or vapor. It is very dangerous to operate the calibrator in such a surrounding.
- Never apply more than 30V between any two terminals, or between any terminal and earth ground.

! Caution

- Disassembly: No one is allowed to remove the split case (top & bottom) of the calibrator except professionals.
- In use: The calibrator can't perform both input

and output simultaneously. No direct connection can be made between both input and output.

- Maintenance: Periodically wipe the case with a damp cloth and detergent; do not use any corrosive solvents.

Note

- To keep the calibrator in a designed accuracy, it needs warming up 5 minutes before it is put into use.
- If the calibrator is not in use, it is recommended to shut down the power supply or keep it in an off-state .In such a way, the battery can prolong its life greatly. During the operation of the output current, do your best to adopt external 24VDC power supply and use the mode of connecting a transmitter, which can prolong the battery life greatly.
- If the user requires a higher accuracy of the calibrator, he should make contact with our manufacturer.



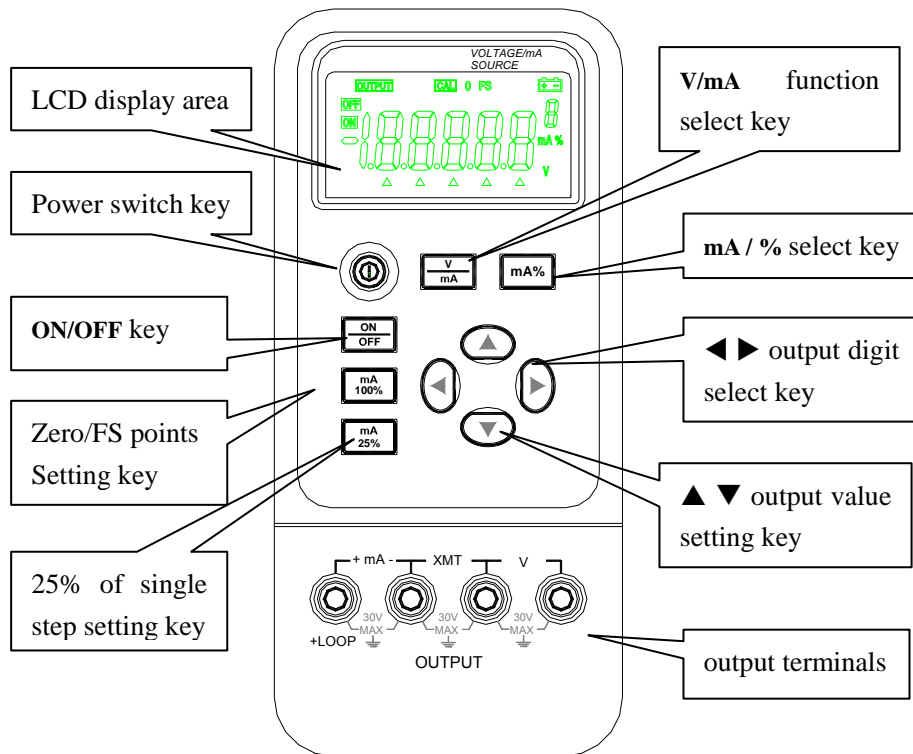

2. Instrument Panel Layout and Function

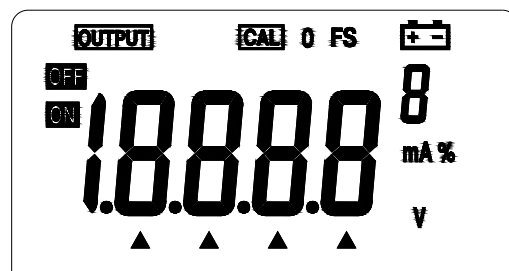

Explanation of LCD Display Area



- a) **OUTPUT:** When this symbol appears in the display, it denotes

- the calibrator in an output state.
- b) : When this symbol appears in the display, it denotes the calibrator in a calibration state.
- c) O FS: This symbol appears when the calibrator is in a state of calibration, denoting that the zero point or the full scale point is now in calibration.
- d) : When this symbol appears, it denotes that the battery is nearly used up and needs replacing now.
- e) : When this symbol appears, it denotes that the output digits need setting.
- f) V, mA, %: These symbols denote the individual units of current output values.
- g) , : These symbols denote that the output signal is turned on or off.

3. Replacing the battery

Warning

- **The test leads must be removed and the power supply of the calibrator must be shut down prior to replacing the battery.**

If the symbol  appears in the display, it denotes that the battery is nearly used up and needs replacing according to the following steps:

- 1) Remove the test leads and shut down power supply of the calibrator.
- 2) Remove the holster from the calibrator. Open the battery cover at the back of the calibrator by releasing the lock in the indicated direction.
- 3) Replace the used-up battery with a new one. Put the battery cover back and lock it in the indicated direction.
- 4) Put the holster back onto the calibrator.

4. Power-On/Off of Calibrator

4.1 Power-key Operation

Press the power key to turn on the power supply of the calibrator. Then press it again to hold it in one second and the power will be off. When the power is turned on, the calibrator starts to make self-diagnosis internally and the full screen is in display. After this, appropriate operation should be carried out.

Note

- **Power-on:** To ensure the correct operation of the calibrator with power on. It is good practice to turn off the power supply pausing 5 seconds, and then restart the calibration.

4.2 Automatic power-off

By the shipping time, the calibrator is set in the factory like this: In case there is no operation of the calibrator within a period of 10 minutes after power-on, it will cut off the power supply automatically. However, users can decide whether they want to use the function of the automatic power-off or not. The setting can also be done by themselves. (See section 6.)

5. Output from calibrator

The appropriate output terminal of the calibrator produces the DC voltage and current set by the user or simulating a transmitter.

! Caution

- During the operation, do not apply voltage to the output terminal. If any improper voltage is applied to the output terminal, it will cause damage to the internal circuit.

Output Operation Procedure

Function Operation	% Operation	Display	Setting Range
DCV 10V ↓		0.000 V	0.0000~11.0000 V 00.000~22.000 mA

DCA	20mA	20mA ↓ %	00.000 mA -025.00 mA %	-025.00~112.50 mA %
-----	------	----------------	---------------------------	---------------------

5.1 DC voltage output

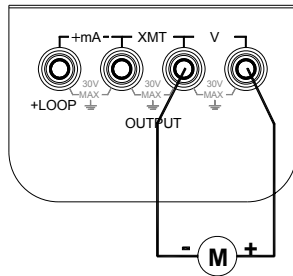

- 1) Insert one end of the test lead into the output jack of the calibrator and connect the other end to the input of the user's instrument as shown in the following diagram.
- 2) When the display indicates the symbol **OUTPUT**, it denotes that the calibrator is in an output state.
- 3) Press the key **(V/mA)** to select the V function and display the unit 'V'.
- 4) Press the key **(◀) / (▶)** to select the set digits for output.
- 5) Press the key **(▲) / (▼)** to change the value of the set digits. The value can do carry or number decrement automatically. Hold the pressed key in one second and the value will be kept varying.
- 6) Press the key **(ON/OFF)** to turn on or turn off the output, and the display indicates the symbol **ON** or **OFF**.

5.2 DC current output

- 1) Insert one end of the test lead into the +mA- output jack of the calibrator and connect the other end to the input of the user's instrument as shown in the following diagram.

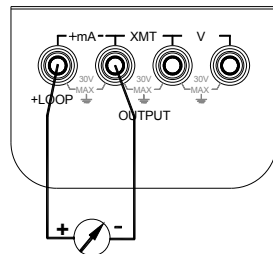

- 2) Press the key **(V/mA)** to select the mA function and display the unit 'mA'.
- 3) Press the key **(mA/%)** to select the output to be set in mA or % and display the unit

'mA%', in which 0% is 4mA and 100% is 20mA.

- 4) Press the key (◀) / (▶) to select the set digits for output.
- 5) Press the key (▲) / (▼) to change the numerical value of the set digits, which can do carry or number decrement automatically. Hold the pressed key in one second and the numerical value will keep varying.
- 6) Press the key (ON/OFF) to turn on/off the output followed by displaying the symbol 'ON' or 'OFF'.

5.3 25% of step current output

- 1) The electric connection is the same as that of the current output.
- 2) Press the key (V/mA) to select the mA function followed by displaying the unit 'mA' or 'mA%'.
- 3) Press the key (mA 25%) to display the symbol 'r'.
- 4) Press the key (mA/ %) to select the output to be set in mA or % followed by displaying the unit 'mA' or 'mA%'.
- 5) Press the key (▲)/(▼) to change the output in a value of 25% , in which 0% denotes 4mA and 100% denotes 20mA. Now press the key (mA 25%) again to exit the step current output.
- 6) Press the key (ON/OFF) to turn on or off the output followed by displaying the symbol 'ON' or 'OFF'.

5.4 Current Output Set for Zero Point & Full Scale

- 1) The electric connection is the same as that of the current output.
- 2) Press the key (V/mA) to select the mA function following by displaying the unit 'mA'.
- 3) Press the key (mA 100%) to display the symbols 'r' and '0 FS'.
- 4) Press the key (mA/ %) to select the output to be set in a certain value of mA or mA% followed by displaying the unit 'mA' or 'mA%'.
- 5) Press the key (▲) / (▼) , which can change the output in a value of 100% , where 0% denotes 4mA and 100% denotes

20mA. Now press the key (mA 100%) again to exit the step current output.

- 6) Press the key (ON/OFF) to turn on/off the output followed by displaying the symbol 'ON' or 'OFF'.

5.5 Simulating Transmitter output (absorption current)

- 1) Insert one end of the test lead into the XMT output jack of the calibrator and connect the other end to the input of the user's instrument and the power supply as shown in the following diagram.
- 2) The key operation is the same as that of DC current output in subsection 5.2.

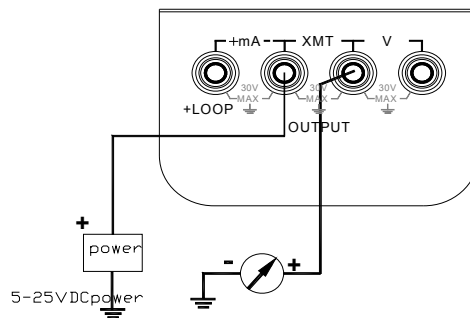

Note

- Range of power supply: 5 to 25VDC
- During the operation at the current output, try your best to use an external 24VDC power source in a mode of connection with a transmitter, thus being able to prolong the battery life.

6. Other Features

The following operation can change the automatic power-off function of the calibrator:

- 1) Turn off the power supply of the calibrator.

- 2) Press the key (**POWER**) when the full screen appears in the display. Now release the (**POWER**) key, and immediately press the key (**mA%**) to enter the calibrator in a maintenance state when the symbol 'AP-XX' appears in the display.
- 3) Press the key (▼) when the symbol 'AP-OF 'appears in the display, denoting that there is no automatic power-off function available to the calibrator. When the symbol 'AP-ON' appears in the display, the calibrator recovers its automatic power-off function.
- 4) Turn off the power supply again to exit the maintenance state.

7. Performance Capabilities

Output Function & Specification :(applicable to temperature range from 18°C to 28 °C , within one year after calibration)

Output	Range	Output Range	Resolution	Accuracy	Remark
DCV	10V	0.000 to 11.000V	1mV	$\pm 0.05\%$ of set value $\pm 2\text{mV}$	Max. output current: 2 mA
DCA	20mA	0.000 to 2.000mA	0.001mA	$\pm 0.05\%$ of set value $\pm 4 \mu\text{A}$	Max. load: 1k Ω at 20mA note 1
Analog transmitter. (absorb. current)	-20mA	0.000 to -22.000mA	0.001mA	$\pm 0.05\%$ of set value $\pm 4 \mu\text{A}$	Max. load: 1k Ω at 20mA
Loop power	24V			$\pm 10\%$	Max. output current: 25mA

Notes: 1. When the battery voltage exceeds 6.8V, the maximum load

is $1\text{K}\Omega$ at 20mA. When its voltage lies between 5.8V and 6.8V, the maximum load is 700Ω at 20mA.

2. Temperature coefficient: $\pm 0.005\%$ of range per $^{\circ}\text{C}$ for the temperature ranges 5°C to 18°C and 28°C to 50°C .

General Specifications

- Power supply: 9V battery (ANSI/NFPA 1604A or IEC 6LR619V alkaline)
- Battery life: ca.12 hours under the condition of 10mA
- Max. permitted voltage: 30V(between any two terminals or between any terminal and earth ground)
- Operating temperature: 0°C to 50°C
- Operating relative humidity: $\leq 80\%$ RH
- Storage temperature: $\leq -10^{\circ}\text{C}$ to 55°C
- Storage humidity: $\leq 90\%$ RH
- Size: $200 \times 100 \times 40$ mm(with holster)
- Weight: 550g (with holster)
- Accessories: operation instruction, a set of CF-36 industrial test lead (with alligator clips attached to probes)
- Option: AC power-supply adapter (VCPS), industrial test lead (CF-31-A with probe clips)
- Safety: Certified as compliant to IEC1010 provisions (Safety standard issued by International Electrotechnical Commission)

8. Calibration

Note

- In order to keep the designed accuracy of the calibrator, it is

recommendable to calibrate your calibrator once a year. The following example shows the use of recommended standard equipment to perform the calibration.

! Caution

- During the operation, never apply more than maximum permitted voltage to the output terminal of the calibrator, otherwise the overvoltage will lead to possible damage to the output section.
- During the operation, avoid short circuit and never apply more than the maximum permitted voltage to the output of the calibrator or to a coworking standard device, otherwise any maloperation will cause possible damage to their internal circuits.

**8.1 Selecting Standard Equipment
Calibrating Output Characteristics**

Calib.Item	Standard Equipment	Input Range	Accuracy	Recommend.
DCV 10V	Digital meter	Max.11v	$\pm (10\text{ppm}+50\mu\text{v})$	1281(FLUKE) or equivalent
DCA 20mA	Digital meter	Max.22mA	$\pm (50\text{ppm}+0.4\mu\text{A})$	

8.2 Ambient Condition for Calibration

Ambient temperature: $23^{\circ}\text{C} \pm 1^{\circ}\text{C}$
 Relative humidity: 45 to 75% RH
 Warming-up:

- Standard equipment must be warmed up to the given time.
- Do not connect the calibrator to the power supply until it has been exposed to the calibrating ambient condition for 24 hours. Then set the calibrator to a non-automatic power off state followed by warming it up to half an hour.

Note

Power supply for calibration: During the calibration, it is good practice to replace the old battery with a new alkaline one.

8.3 Operation Output Calibration

Operating calibration in order of items and calibration points in the following table:

Item No.	Output Range	Calib.Point
1	DCV/10V	O
		FS
		O FS
2	DCA/20mA	O
		FS

8.3.1 Calibrating 10V range

- 1) The calibration wiring diagram is shown in the following diagram:

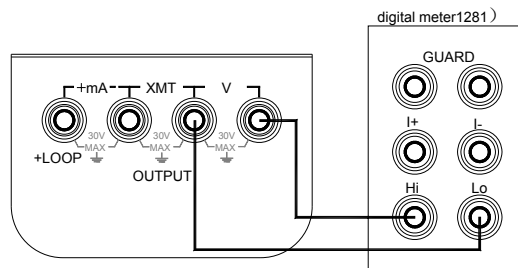

- 2) First press the two keys (**V/mA**) and (**mA%**) simultaneously ,and then press the key (**POWER**) to enter the calibrator in a state of calibrating 10V output when the symbols 'OUTPUT', 'CAL 0', 'ON' and the unit 'V' appear in the display.
- 3) Set the digital meter to a corresponding range.
- 4) With the output stabilized, operate the keys (**◀**) / (**▶**) and (**▲**) / (**▼**) to set the indication of the calibrator in identity with the reading of the digital meter.
- 5) Press the key (**mA 25 %**) to start flashing in the display,

denoting the calibrated point has been stored.

- 6) Press the key (mA/%) and the display will indicate the symbol 'CAL FS'. With the output stabilized, repeat the steps 4 and 5.
- 7) Now press the key (mA/%) again and the display will indicate the symbol 'CAL 0 FS'. With the output stabilized, repeat the steps 4 and 5.

Note

Calibration storage :Press the key (25%) to store the calibrated point when the display does not start flashing, denoting that the calibration storage is invalid.

8.3.2 Calibrating 20mA range

- 1) The calibration wiring is shown in the following diagram:

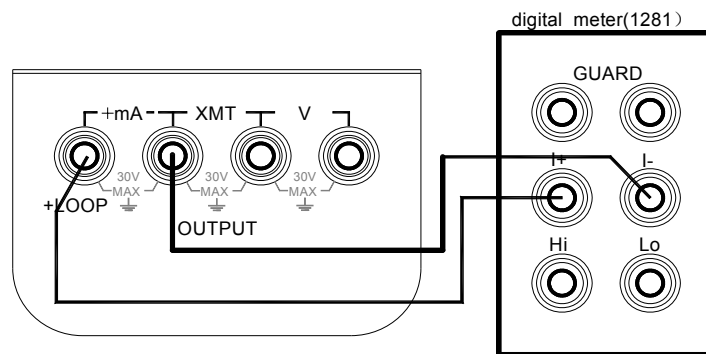

- 2) Press the key (V/mA) to enter the calibrator in a state of 20mA output calibration, and then the symbols 'OUTPUT', 'CAL 0', 'ON' and the unit 'mA' appear in the display.
- 3) Repeat the steps from 3 to 6 in subsection 8.3.1.
- 4) Turn off the power supply again to exit the calibration state.

9. Points for Attention to Use of Operation

Instruction

- The present operation instruction is subject to change without notice.
- The content of the operation instruction is regarded as correct. Whenever any user finds its mistakes, omission, etc., he or she is requested to make contact with the manufacturer.
- The present manufacturer is not liable for any accident and hazard arising from any maloperation.
- The functions described in this operation instruction should not be used as grounds to apply this product to a particular purpose.

MB-0004-01